

9 Criteria for Choosing a 3D CAD System

BY L. STEPHEN WOLFE, P.E.

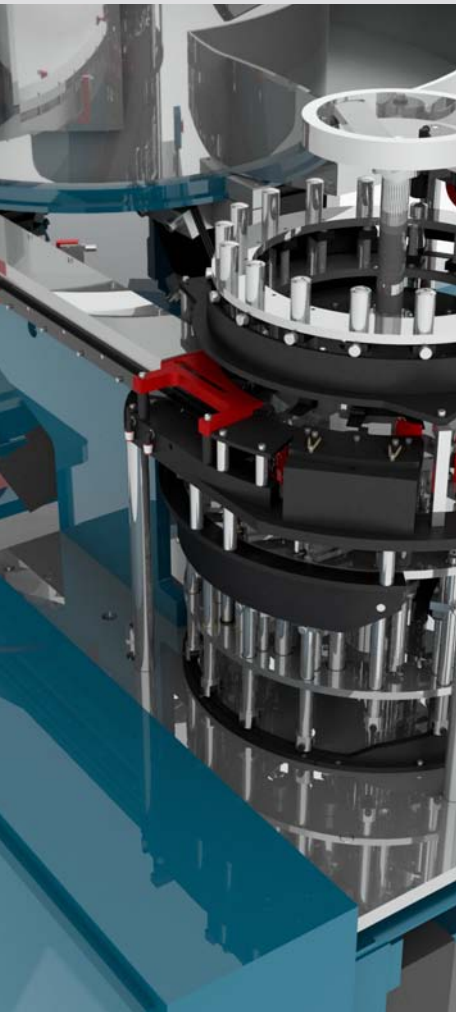
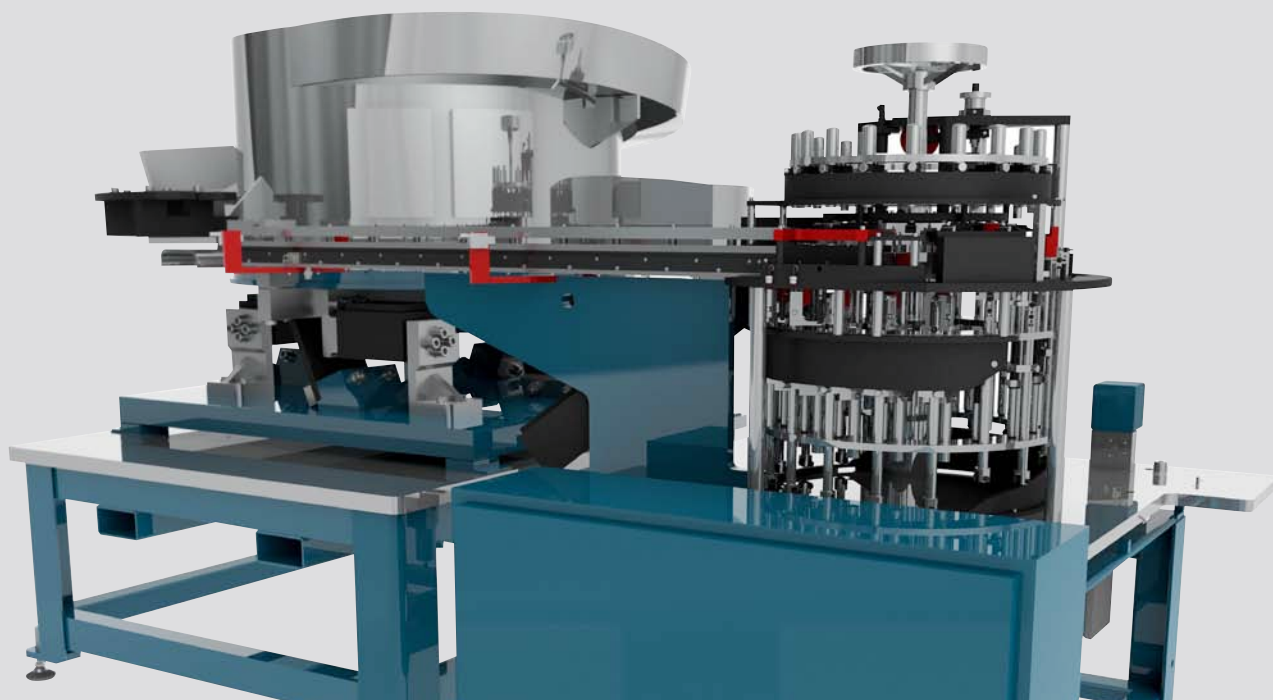

SUMMARY

In the discrete manufacturing industries, between one-third and one-half of the CAD systems in use today are 3D. The rest are used for 2D computer-aided drafting¹. Although some tasks will always be done more efficiently with 2D CAD, these figures suggest many organizations have yet to employ 3D methods.

The good news for potential second-half adopters is that they can benefit from the wisdom and experience of engineers who've been using 3D methods for 10 or 20 years. The following is a compilation of 9 criteria that users of 2D CAD should consider when shopping for their first 3D system².

1. Capable, efficient 3D design

The centerpiece of 3D CAD is a 3D master model that's used for all aspects of manufacturing: product design and verification, drafting, tool design, numerically controlled tool programming, and inspection. The 3D model must accurately represent every part in your company's products and the relationships among them. To maximize efficiency, designers should be able to design in 3D with as few steps as possible without compromising product quality.

When evaluating CAD software, find out how efficient each package is at creating the types of products your company makes.

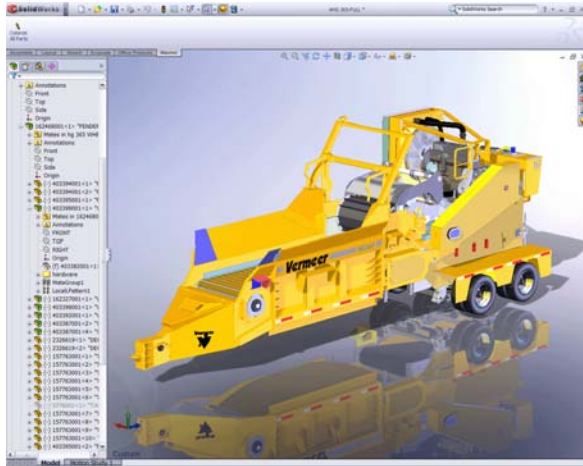

3D CAD MODEL OF A HORIZONTAL GRINDER (IMAGE COURTESY OF VERMEER ENVIRONMENTAL EQUIPMENT OF PELLA, IOWA)

When evaluating CAD software, find out how efficiently each package creates the types of products your company makes. For example, if your company makes sheetmetal parts, pay attention to the special tools for creating them and automatically generating flat patterns. If your firm designs stylish products, look at the tools for creating freeform surfaces and blends between them. Designers of machinery should see how easy it is to assemble large numbers of parts and insert purchased parts such as fasteners from a library.



3D MODEL OF A PREMACARE INCUBATOR (IMAGE COURTESY OF 360 GRADER PRODUKTDESIGN OF OSLO, NORWAY)

Because changes are inevitable, assess how hard it is to modify parts and assemblies. A CAD system that can make your company's designs with even 20 percent fewer steps will offer important cost advantages compared with systems that are less efficient. A 3D CAD system that offers the best value will combine exceptional technical capabilities with reasonable cost of ownership.

2. Compatibility with customers and suppliers

In today's world, few manufacturers are vertically integrated. Most rely on a community of suppliers for parts, tools, subsystems, production equipment, and design services that frequently span the globe. Whether your company is a supplier or a customer, it can benefit from exchanging 3D CAD files with customers and suppliers.

When possible, choose a CAD system that's popular in your industry and supplier community.

When possible, choose a CAD system that's popular in your industry and supplier community. This choice will eliminate the need to translate files from one system to another. Translation takes time and sometimes introduces errors.

Also look at each system's ability to import files from other systems. Make sure your CAD supplier supports international standards such as STEP, IGES, VDA, and IDF. Evaluate the tools for repairing damage to imported shapes, how easy they are to use, and how well they work. If your firm must translate many files from several brands of CAD systems, check out the direct translators available with each CAD system and also those from third parties that specialize in translation software.

Don't limit your evaluation of data exchange capabilities to product geometry. Find out how convenient it is to import or export file properties and bills of materials.

Exchanging CAD files with customers or suppliers can save thousands of hours and weeks of schedule time compared with the cost of redrawing them interactively. The ability to collaborate in three dimensions on products and processes can reduce costs while helping to deliver better products.

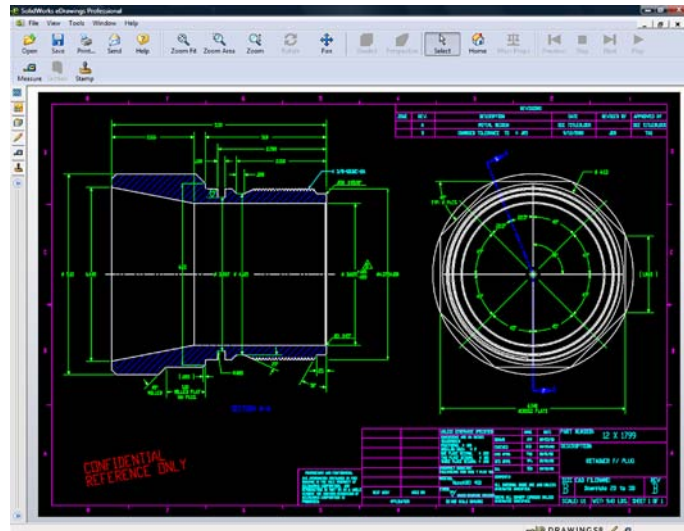

DATA EXCHANGE TOOLS LIKE SOLIDWORKS EDRAWINGS® ALLOW USERS TO COLLABORATE WITH CUSTOMERS AND SUPPLIERS.

3. Drafting tools that meet your standards

Even though you'll be designing in 3D, your suppliers and factory workers will need drawings. A clear drawing shows information that isn't obvious in a 3D model: critical dimensions and tolerances, material and surface-finish specifications, and notes about processing such as curing or heat treatment. Be sure any 3D CAD system you buy can make drawings to your current standards for dimensions, tolerances, lettering, and parts lists. And be sure your drawings can be exported in popular formats such as PDF, DXF, and DWG.

Be sure any 3D CAD system you buy can export your drawings in popular formats such as PDF, DXF, and DWG.

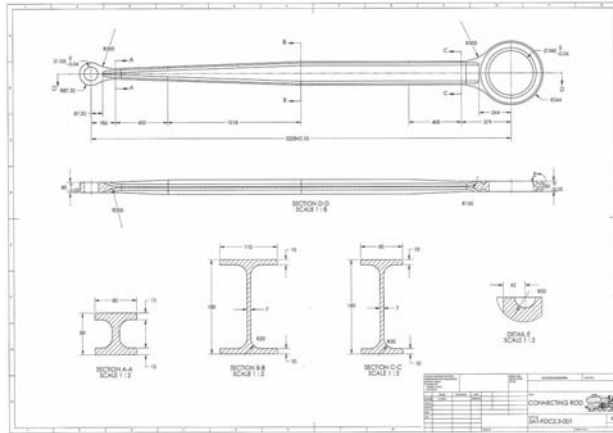

DETAILED ENGINEERING DRAWING OF A CONNECTING ROD FOR A STEAM LOCOMOTIVE, (IMAGE COURTESY OF DAVID WARDALE OF THE 5AT PROJECT)

4. Reliability and stability

3D design systems are more complex than 2D drawing systems. With all that code, it's harder to get the bugs out. Unfortunately there are no standard measures of reliability for CAD as there are for many types of systems and machinery. Browse customer forums for frequent reports about instability or software bugs. Ask companies that own 3D CAD in your city or industry how often they crash or lock up.

If your company makes large assemblies, be sure any CAD system you buy is capable of handling them efficiently. Some systems slow to a crawl when handling complex designs with high part counts. Pay particular attention to assembly performance if your products contain complex freeform shapes, helical sweeps, or arrays of holes or other features.

If you need to simulate physical behavior such as kinematics, dynamics, stress, deflection, vibration, temperatures, or fluid flow, look for a system that has integrated analytical tools or efficient interfaces to your preferred analysis software.

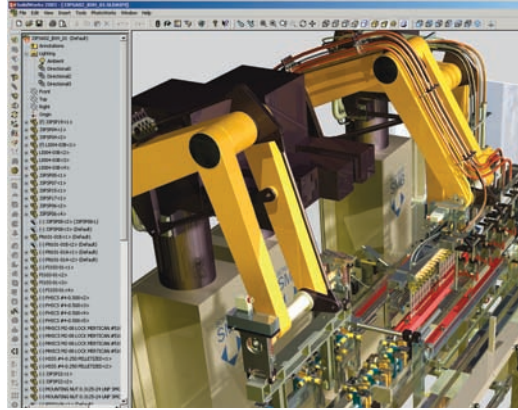

MAKE SURE YOUR 3D CAD SYSTEM CAN HANDLE DESIGNING LARGE ASSEMBLIES (IMAGE COURTESY OF GERHARD SCHUBERT GMBH OF GERMANY)

5. Pleasant business relationships

Believe it or not, some of the greatest sources of friction between buyers of CAD software and their customers are the nontechnical business aspects of the relationship. Just as some airlines annoy customers with extra fees for checked baggage, flight changes, drinks, and blankets, some CAD suppliers levy hidden charges for software and services that most customers need.

To avoid aggravation and lower your costs, look for suppliers who offer straight-forward software packages that have everything you need. Look at the terms for floating licenses that enable designers who don't need CAD full-time to share licenses. And be sure your best designers can use the software both at work and at home without hassles.

6. Built-in applications that help your business

3D CAD can be even more productive with special-purpose software for design automation and analysis. If you need to simulate physical behavior such as kinematics, dynamics, stress, deflection, vibration, temperatures, or fluid flow, look for a system that has integrated analytical tools or efficient interfaces to your preferred analysis software.

Does your company make products that are variants of a common type such as molds, stamping dies, conveyors, or production equipment? If so, look for a supplier that has integrated software to automate the design of your products.

Organizations with more than just a few designers need product data management (PDM) software integrated with their CAD tools. Files from 2D CAD systems can be organized in file directories. But because relationships among files in 3D systems are so complex, an automated system to store and organize them is necessary. Without PDM, designers can unknowingly overwrite each other's work and waste hundreds of hours each year.

Choose a system with built-in tutorials, a rich array of computer-based training aids, and a vibrant online community that lets workers ask questions and get answers.

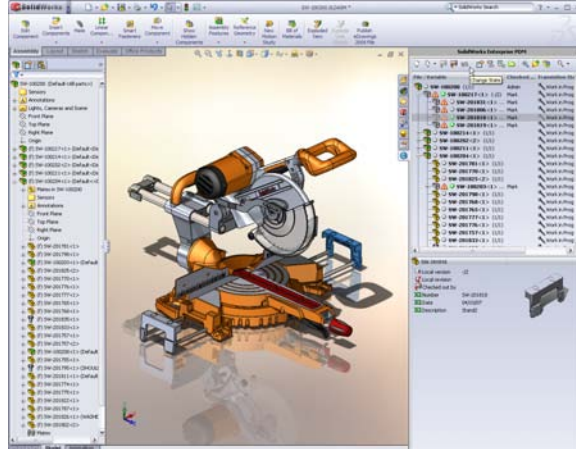

INTEGRATED PDM SOFTWARE ENABLES GROUPS OF DESIGNERS TO WORK TOGETHER EFFICIENTLY ON COMMON PROJECTS.

PDM systems can do much more than just store and organize files. They can help designers find existing parts to re-use instead of reinventing them. PDM systems also generate material lists for cost estimating and feed data to manufacturing resource planning (MRP) systems. More advanced PDM software can automate change-control processes to assure that out-of-date or unreleased information isn't sent to factories or suppliers.

Lastly, make sure any system has a complete and well-documented application programming interface (API). Good APIs let you write your own design-automation programs. They also make it less costly for third parties to integrate niche applications with your CAD system.

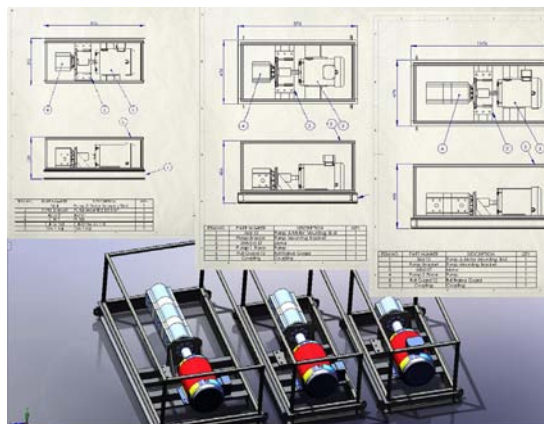

DESIGN AUTOMATION ALLOWS REUSE OF EXISTING DESIGNS TO CREATE NEW CONFIGURATIONS, INCLUDING 3D CAD MODELS, DRAWINGS, AND BILLS OF MATERIAL.

Buy from a dealer with the skills and experience to help you make the transition to 3D design.

7. Short learning curve

Adopting 3D methods requires training and experience. So choose a system that's easy to learn as well as capable. Look for a system that has a consistent user interface throughout. Be sure design and drafting procedures flow logically from start to finish. Some systems have hidden dungeons and dragons that stop designers halfway through a task and make them start over.

Developing your own training materials is costly. Choose a system with built-in tutorials, a rich array of computer-based training aids, and a vibrant online community that lets workers ask questions and get answers. You'll also want a system that's taught in local schools and universities so you can hire students who are ready to work.

8. Innovative R&D to protect your investment

Computing technology is constantly changing. If your CAD vendor doesn't take advantage of this evolution, in a few years you'll find that your organization has an obsolescent and costly-to-maintain CAD system. Buy from suppliers that have a proven record of being manufacturing industry leaders with large and sophisticated R&D teams.

9. A dealer who can help you

A successful relationship with your CAD software dealer only begins with the sale. Buy from a dealer with the skills and experience to help you make a successful transition to 3D design. Find out how many 3D customers potential dealers have trained and supported. Look at the availability of quality training classes. Does the dealer support a viable user group? Does the reseller offer ongoing training classes to help you improve your design and manufacturing processes?

Ask for the resumes of the technical staff and interview them before you buy. Ask reference customers if the dealer's technical staff is capable of solving tough problems. Good local support can make the difference between a scary and unproductive adoption of 3D and one that advances your business objectives now and in the future.



EXPERIENCED DEALERS CAN HELP CUSTOMERS WHO ARE NEW TO 3D BECOME PRODUCTIVE QUICKLY. (IMAGE COURTESY OF CADVENTURE, INC., OF WILLOUGHBY, OHIO)

Engage with at least three vendors to educate yourself about the capabilities of available software packages and dealer support organizations.

One size doesn't fit all

Not all the criteria listed above apply to every organization. Making an intelligent choice requires careful thought and deep knowledge of your company's engineering needs.

The biggest mistake any organization can make is to select a 3D system without shopping. Engage with at least three vendors to educate yourself about the capabilities of available software packages and dealer support organizations. It's tragic when companies must buy 3D systems twice. Such organizations usually make an emotional decision based on brand preference or focus on too few criteria. When they find that their hastily chosen 3D system can't do what they need or requires them to work around functional inadequacies, they're forced to buy and learn new tools.

¹Based on analysis by CAD/CAM Publishing, Inc. of publicly reported financial data.

²Based upon interviews and surveys by the author of engineers who use 3D CAD systems.

L. Stephen Wolfe is a professional mechanical engineer based in San Diego, California. He was founder and publisher of *Computer Aided Design Report* and *Product Data Management Report* (now CAD/CAMNet online). For more than 20 years, these publications filled the role of *Consumer Reports* for the CAD industry. Wolfe has written two books on how to pick CAD/CAM systems: *The Smart Manager's Guide to Selecting and Purchasing CAD Systems* and *The CAD/CAM Strategic Planning Guide*. He currently consults in the mechanical engineering software field, assisting customers in defining their requirements, conducting independent research, identifying and negotiating with software suppliers, and implementing new software efficiently.



Dassault Systèmes SolidWorks Corp.
300 Baker Avenue
Concord, MA 01742 USA
Phone: 1 800 693 9000
Outside the US: +1 978 371 5011
Email: info@solidworks.com

www.solidworks.com